

PRECISION PLANTING BULLSEYE SEED TUBE MOUNTING INSTRUCTIONS

John Deere, Kinze, and White Planters
 (Read Instructions Completely before Beginning Installation)

Before working on your planter or drill

DANGER: when storing or working on the planter always install cylinder stops or place the planter on stands to prevent personal injury or damage to the Rebounder. **WARNING:** do not roll back or back up the planter in or on the ground as this can result in damage to the Rebounder.

Mounting Instructions

Follow the standard Rebounder Mt. Instructions for John Deere, Kinze, and White Planters EXCEPT for steps# 1,2,&3 below. The following instructions can be used to assist you in mounting the Rebounder Seed Cover to the Precision BullsEye Seed Tube.

Use the table below to identify the type of BullsEye Seed Tube you have.

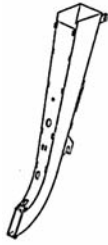
Types of Precision BullsEye Seed Tubes					
Part # located on back of seed tube	Sensor Type	Used on	seed tube top opening dimension		
			A	B	
700114	Standard	MaxEmerge™, MaxEmerge 2, * Kinze	2-1/4"	1-3/4"	
700110	High-rate	MaxEmerge™, MaxEmerge 2, * Kinze	2-1/4"	1-3/4"	
700133	Standard	MaxEmerge™, MaxEmerge* Plus	3"	2-1/4"	
700130	High-rate	MaxEmerge™, MaxEmerge* Plus	3"	2-1/4"	
700118	Standard	White 6000 & 8000	2-1/4"	1-3/4"	

* = ☉

- Step #1:** take saw tooth insert out of Rebounder. Cut 1" off saw tooth inserts long slotted end (**fig. (a)**) with a hack saw.
- Step #2:** place saw tooth insert back into Rebounder with short slotted end to the top of the Rebounder and the cut end down (**fig. (b)**).
- Step #3:** place Rebounder over the 2 shark fins sticking up on the back side of the BullsEye seed tube. This will hold the Rebounder in place. The Rebounder will come within 1/8" of resting tight against the seed tube. Don't grind the clips off that hold the seed tube together. Grind half moon notches in the Rebounder backside where clips protrude on the seed tube **fig. (c)**. The tie straps will hold the Rebounders in place and let it perform properly.
- Step #4:** using the 2 tie straps provided, strap the Rebounder to the seed tube. The long part of the tie strap should extend out the back of the seed tube and not to the side of the seed tube. Pull the tie straps tight with a pliers, and cut off the excess length.
- Step #5:** re-install the BullsEye seed tube back in the planter.

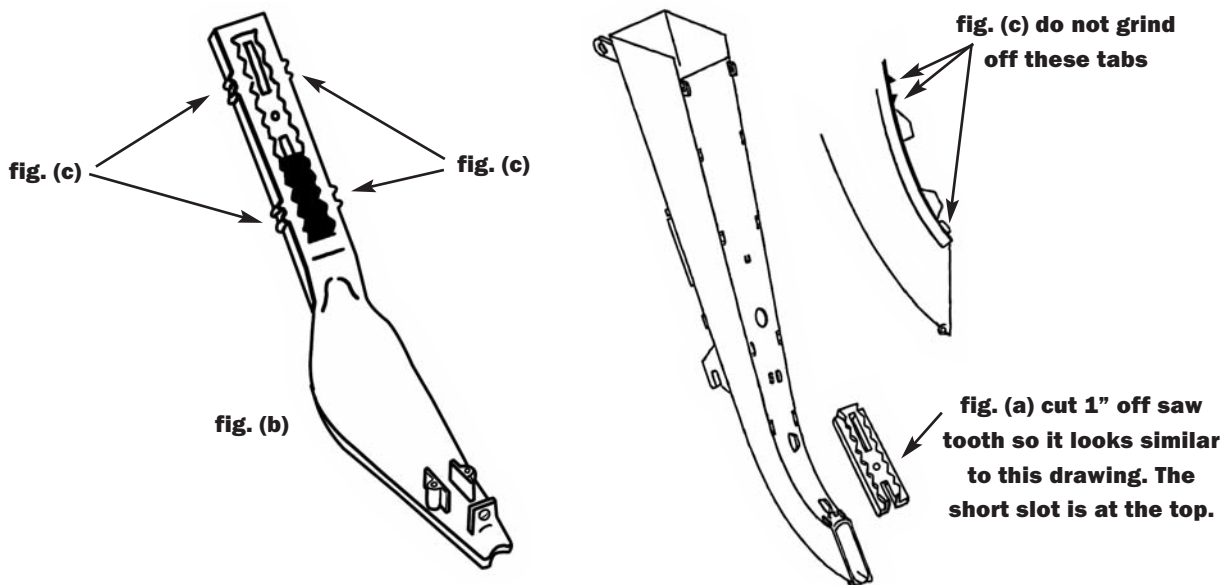

2009 BULLSEYE SEED TUBE OR PRECISION SEED TUBE MOUNTING INSTRUCTIONS FOR PART NUMBERS:

#700150 for JD 7000, Kinze, Grt.Plains pltrs., #700155 for White Series pltrs.

#700158 for Monosem pltrs., #700160 for JD 7200-1700 series

(Read Instructions Completely before Beginning Installation)

Before working on your planter or drill

DANGER: when storing or working on the planter always install cylinder stops or place the planter on stands to prevent personal injury or damage to the Rebounder. **WARNING:** do not roll back or back up the planter in or on the ground as this can result in damage to the Rebounder.

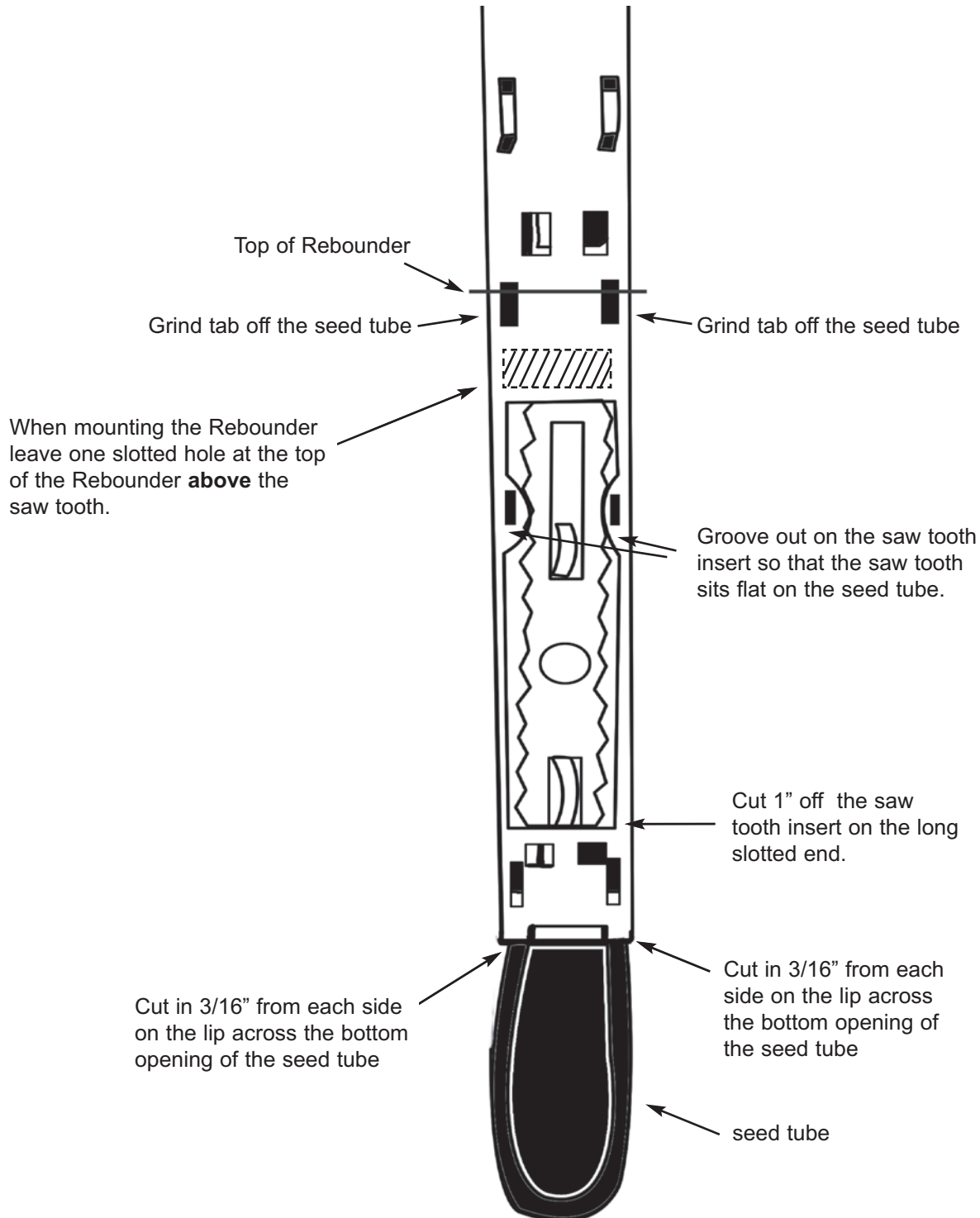

Rebounder covered by one or more of the following U.S. patents: 5,640,915; 5,918,557; 6,082,275; 6,283,050; 6,453,832; 6,763,773 and 7,121,216.