

**REBOUNDER™ MOUNTING INSTRUCTIONS**

Case IH Drills 5300, 5400, 5500, and some 5100 Series

(Read Instructions Completely before Beginning Installation)

**Before working on your planter or drill**

**DANGER:** when storing or working on the planter always install cylinder stops or place the planter on stands to prevent personal injury or damage to the Rebounder. **WARNING:** do not roll back or back up the planter in or on the ground as this can result in damage to the Rebounder.

**Mounting Instructions**

Before you begin locate the "package contents" list to verify all items are included.

**Important Points to Remember:**

- The molded in tab is for in - furrow applications. Optional Quick Couplers are also available upon request for a small charge. The NEW Straight Shot fitting is used for keeping fertilizer from building up on the press wheel. This puts fertilizer directly on the seed and should be used when you notice excessive soil and fertilizer build up on the press wheel tire.
- It is necessary for you to cut off one or two holes from the Rebounder to make it fit into your particular drill (**fig. (d)**). If you don't cut the top hole(s) off they will rub on the rivets on the inside of the discs and can stop them from turning.
- **See HELPFUL HINTS FOR MOUNTING REBOUNDERS TO DRILLS**

**Step #1:** remove one disc from each row, it is not necessary to remove scrapers.

**Step #2:** mount Rebounder bracket over 5/16" hole on frame of drill using the 5/16" x 1 1/4" bolt. Insert bolt through holes putting 5/16" lock nut on bolt with wrench. Use a piece of tape to hold the nut in place between the disc and frame (**fig. (a)**). Hold the bracket down while tightening the bolt in place. Either tap a small wedge (provided) into the top of the bracket and weld to bracket (**fig. (b)**), or tack weld the bracket to the drill frame so the bracket can not flex up when in use.

**Step #3:** now you can mount the first Rebounder to the bracket.

**EXAMPLE:** with new discs on the drill and the press wheel adjusting handle in the 2nd notch from the back of the drill, a good starting point would be to try the 2nd and 3rd holes up from the bottom of the Rebounder (**fig. (c)**). use the 1st and 3rd holes up from the bottom on the bracket. Attach the Rebounder to the bracket with the two 1/4" x 1" bolts. If the discs are worn, make adjustments accordingly. Replace your discs when finished mounting the Rebounder.

**NOTE:** Position the Rebounder so that the tail end will be from 3/8" to 1/2" off of the ground or floor.

Rebounder Package Contents (per single row)	
Item	Quantity
Rebounder . . . . .	1
L-bracket . . . . .	1
1/4x1" bolts . . . . .	2
1/4" whiz nut . . . . .	1
1/4" nut . . . . .	1
Instruction Sheet . . . . .	1

Bracket Package Contents (per single row)	
Item	Quantity
Bracket . . . . .	1
5/16x1 1/4" bolt . . . . .	1
5/16" lock nut . . . . .	1
Metal wedge . . . . .	1

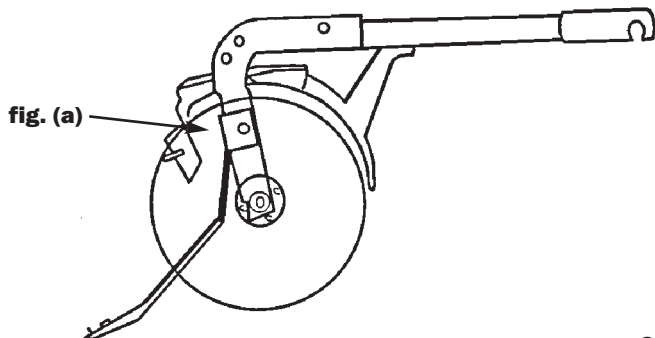

**Straight Shot  
Optional Fitting**

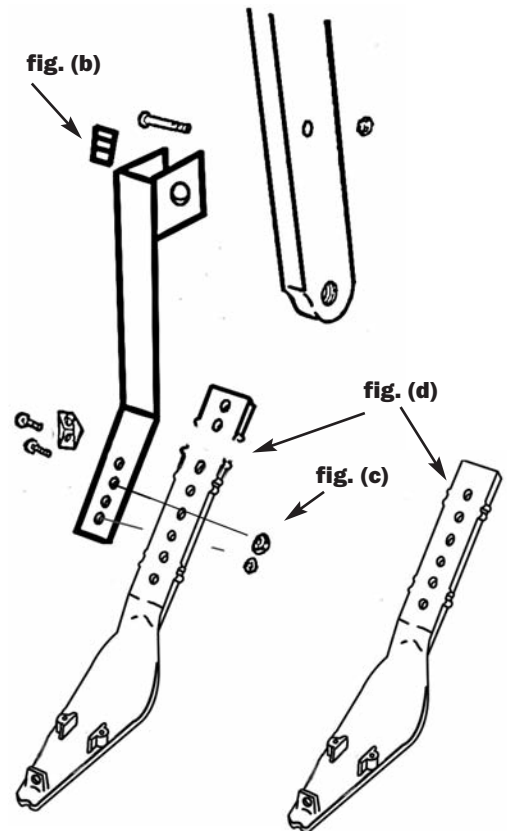

Rebounder covered by one or more of the following U.S. patents: 5,640,915; 5,918,557; 6,082,275; 6,283,050; 6,453,832; 6,763,773 and 7,121,216.

## **HELPFUL HINTS FOR MOUNTING THE REBOUNDER™ ON DRILLS**

(Read Instructions Completely before Beginning Installation)

### **Before working on your planter or drill**

**DANGER:** when storing or working on the planter always install cylinder stops or place the planter on stands to prevent personal injury or damage to the Rebounder. **WARNING:** do not roll back or back up the planter in or on the ground as this can result in damage to the Rebounder.

### **Helpful Hints**

- Step #1:** use a farm jack on the press wheel to raise up the drill unit 3-4" before you mount the first row.  
**IMPORTANT:** have press wheel adjusting handle of knob, in the position you would normally run in the field (see **fig (a)**).
- Step #2:** slide a board or piece of flat iron under the double disc openers and back under the press wheel tire. The board or flat iron represents the bottom of the seed V.
- Step #3:** now you can bolt the Rebounder to the bracket on the drill. Position the Rebounder on the bracket so that the trailing end will be from 3/8" - 1/2" off the board or flat iron. Using the 1/4" bolts attach the Rebounder to the bracket on the drill.
- Step #4:** variances in the disc blade size will occur among individual drills as well as within any single drill. Measure discs behind the tire track rows. If they are worn more than other rows this process may need to be used to set these rows also.
- Step #5:** if replacing Rebounders on previously installed brackets, simply remove the old Rebounder without removing the disc blade. Using a small bar magnet or a long handled magnet, place the bolt on the magnet and slide it up between the discs and into the holes of the bracket and the Rebounder. This allows you to come in behind with a wrench or socket to install and tighten the nuts.

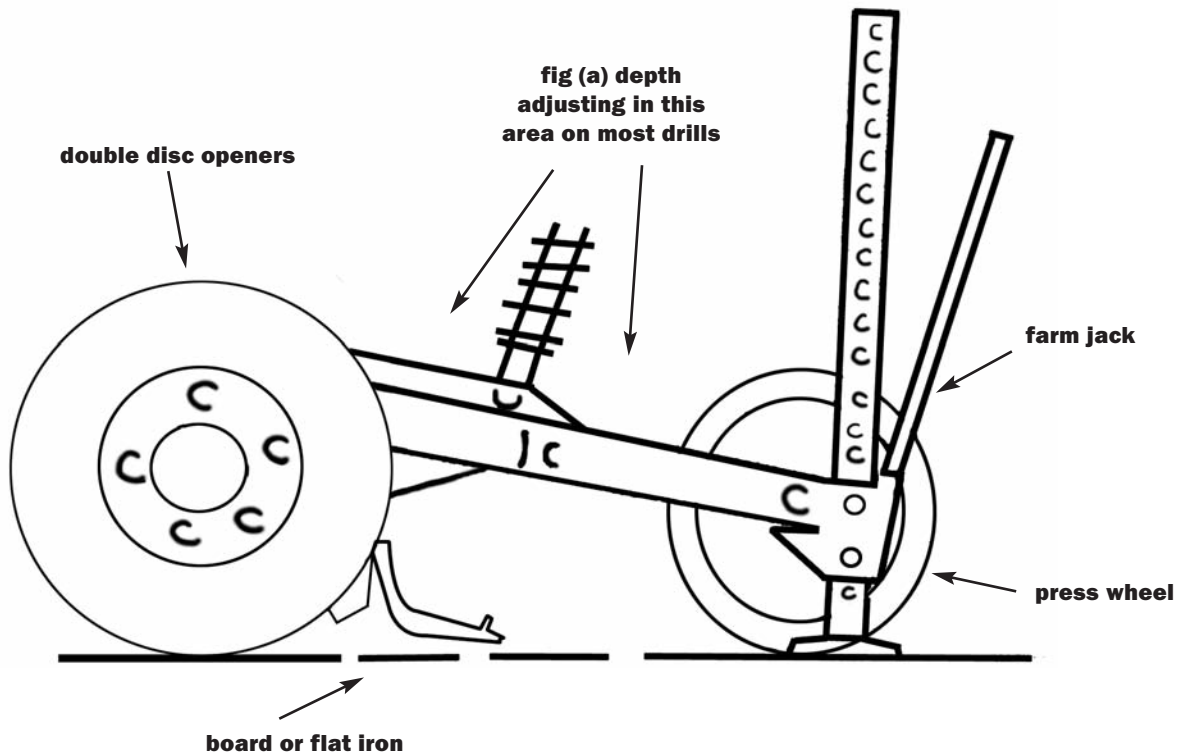

Rebounder covered by one or more of the following U.S. patents: 5,640,915; 5,918,557; 6,082,275; 6,283,050; 6,453,832; 6,763,773 and 7,121,216.