

REBOUNDER™ MOUNTING INSTRUCTIONS

UFT 5200 Series Drills

(Read Instructions Completely before Beginning Installation)

Before working on your planter or drill

DANGER: when storing or working on the planter always install cylinder stops or place the planter on stands to prevent personal injury or damage to the Rebounder. **WARNING:** do not roll back or back up the planter in or on the ground as this can result in damage to the Rebounder.

Mounting Instructions

Before you begin, verify all items listed in the “package contents” table.

NOTE: See **HELPFUL HINTS FOR MOUNTING REBOUNDERS TO DRILLS.**

- Step #1:** remove one disc from each row. Remove the rotary scraper. Using the 5/16 x 1 1/4” bolt mount the Rebounder bracket under where the rotary scraper was. The Rebounder bracket acts as a scraper if you don’t want to use the rotary scraper.

- Step #2:** **SETTINGS:** for example - mount the Rebounder on the bottom side of the UFT bracket. A good starting position would be to put the bolts in the Rebounder in the 3rd and 4th holes up from the bottom of the Rebounder, and the 2nd and 4th holes up from the bottom of the bracket. Make sure the tail of the Rebounder is 3/8” to 1/2” off the bottom of the seed V. Adjust accordingly when mounting to worn discs.

- Step #3:** if applying fertilizer place L-bracket in bottom hole of both the Rebounder, use flange nut on this bolt.

Rebounder Package Contents (per single row)	
Item	Quantity
Rebounder.	1
1/4 x 1” bolts	2
L-bracket.	1
Nut	1
Whiz nut	1
Instruction Sheet.	1
Bracket Package Contents (per single row)	
Item	Quantity
Bracket	1
5/16 x 1 1/4” bolt	1
Lock nut	1

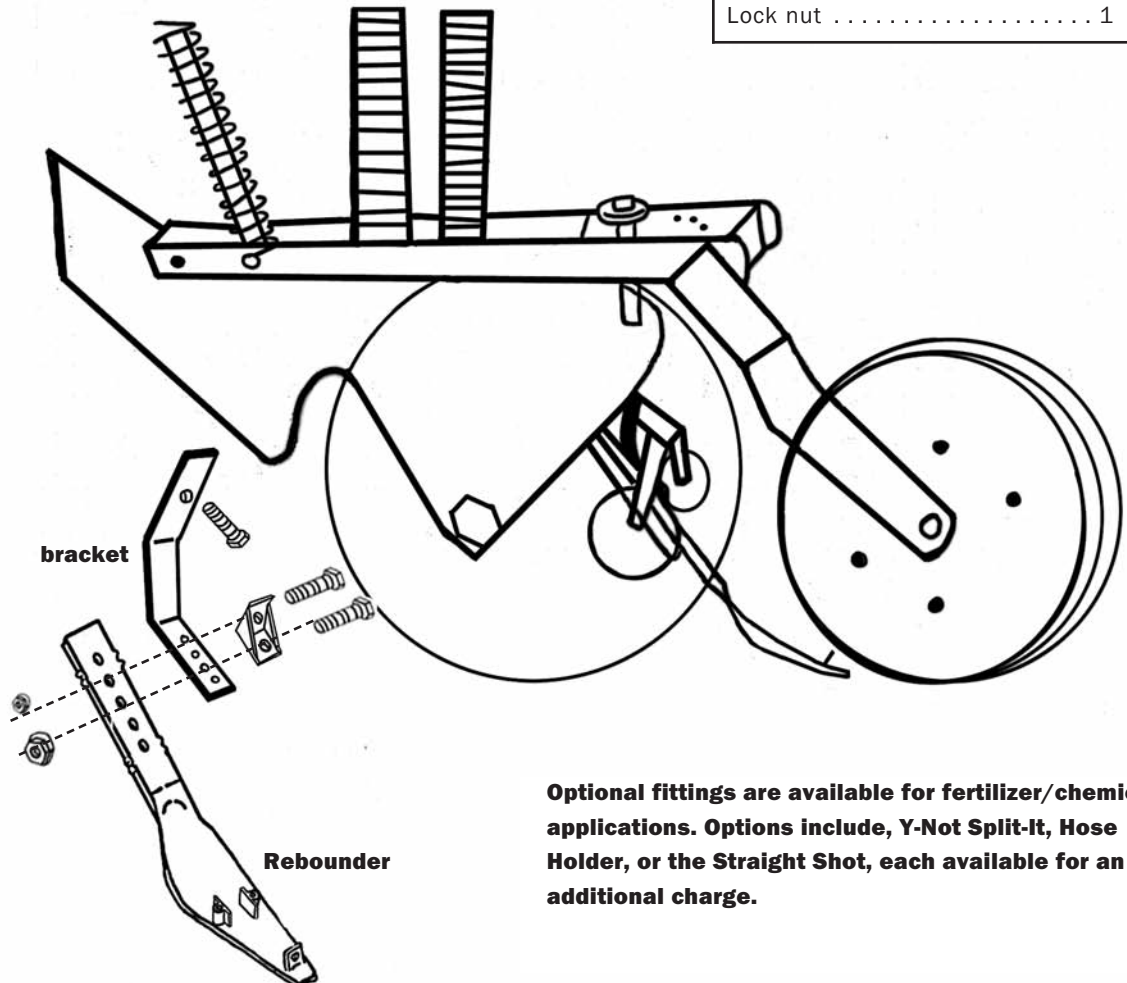

Optional fittings are available for fertilizer/chemical applications. Options include, Y-Not Split-It, Hose Holder, or the Straight Shot, each available for an additional charge.

Rebounder covered by one or more of the following U.S. patents: 5,640,915; 5,918,557; 6,082,275; 6,283,050; 6,453,832, 6,763,773 and 7,121,216.

HELPFUL HINTS FOR MOUNTING THE REBOUNDER™ ON DRILLS

(Read Instructions Completely before Beginning Installation)

Before working on your planter or drill

DANGER: when storing or working on the planter always install cylinder stops or place the planter on stands to prevent personal injury or damage to the Rebounder. **WARNING:** do not roll back or back up the planter in or on the ground as this can result in damage to the Rebounder.

Helpful Hints

- Step #1:** use a farm jack on the press wheel to raise up the drill unit 3-4" before you mount the first row.
IMPORTANT: have press wheel adjusting handle of knob, in the position you would normally run in the field (see **fig (a)**).
- Step #2:** slide a board or piece of flat iron under the double disc openers and back under the press wheel tire. The board or flat iron represents the bottom of the seed V.
- Step #3:** now you can bolt the Rebounder to the bracket on the drill. Position the Rebounder on the bracket so that the trailing end will be from 3/8" - 1/2" off the board or flat iron. Using the 1/4" bolts attach the Rebounder to the bracket on the drill.
- Step #4:** variances in the disc blade size will occur among individual drills as well as within any single drill. Measure discs behind the tire track rows. If they are worn more than other rows this process may need to be used to set these rows also.
- Step #5:** if replacing Rebounders on previously installed brackets, simply remove the old Rebounder without removing the disc blade. Using a small bar magnet or a long handled magnet, place the bolt on the magnet and slide it up between the discs and into the holes of the bracket and the Rebounder. This allows you to come in behind with a wrench or socket to install and tighten the nuts.

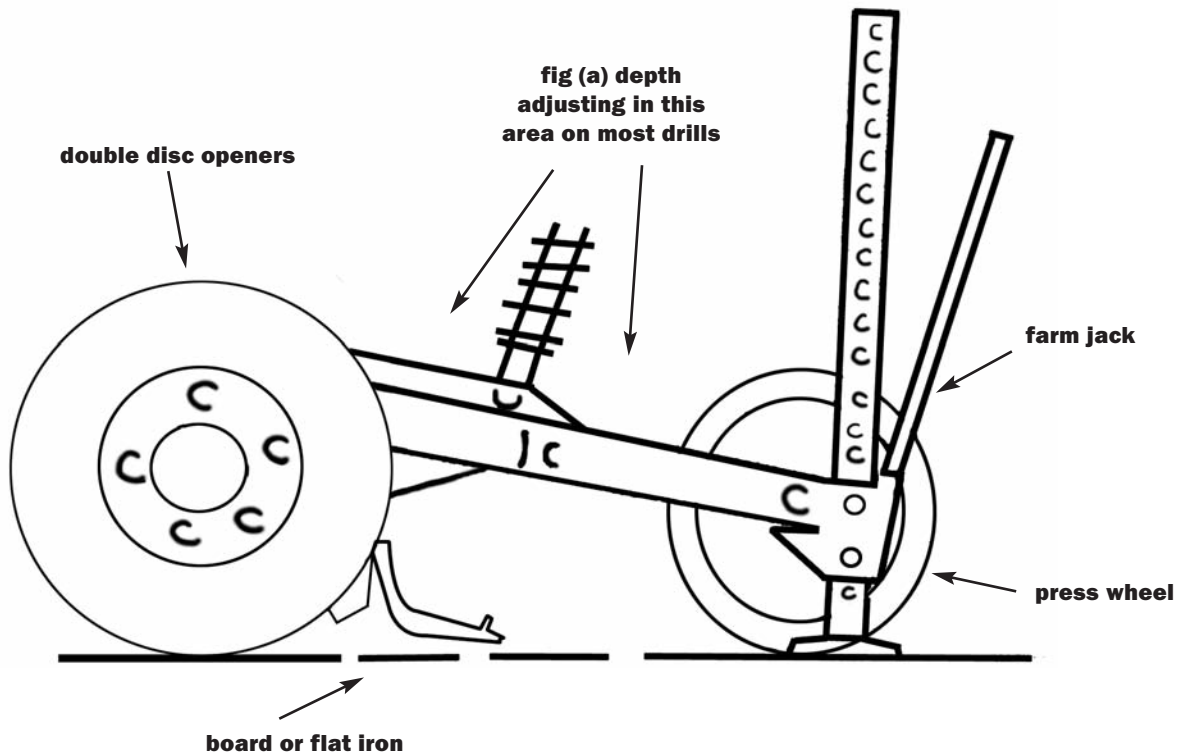

Rebounder covered by one or more of the following U.S. patents: 5,640,915; 5,918,557; 6,082,275; 6,283,050; 6,453,832; 6,763,773 and 7,121,216.