

FURROW V CLOSER MOUNTING INSTRUCTIONS

White 6000 Series Angular Planters
(Read Instructions Completely before Beginning Installation)

Before working on your planter or drill

DANGER: when storing or working on the planter always install cylinder stops or place the planter on stands to prevent personal injury or damage to the attachments. Do not allow planter to rest on poly FVC discs as they can warp

Mounting Instructions

Before you begin, verify the "package contents" to ensure all items are included.

Step #1: Assemble the Furrow V Closer. Begin by removing the two 3/8" square headed set bolts from the mounting bracket and install the two 3/8" jam nuts. Remove the left side press wheel. Mount the FVC bracket with the 5 1/2" bolt, then drill a 3/8" hole at the rear of the mounting bracket on 1996 and older planters (**fig. (a)**). On late 1996 and newer models, it is not necessary to drill any holes; they are already in the planter bracket. Install two 3/8 x 1 1/4" bolts with locknuts and tighten. The 3/8" nut used on the middle hole may have to be ground down a little so the bolt can be screwed into it from the inside (**fig. (b)**).

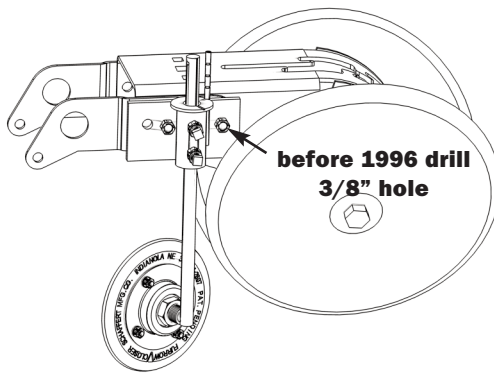

Step #2: Install the poly disc to all-thread of shaft using a 3/4" jam nut on each side of the disc. Inward and outward adjustment is made with the 3/4" jam nuts. Start at a distance of 3/4" between the hub and shaft (**fig. (c)**). **Ex.:** use a 1/2" hex sided nut from your bolt bin and place it between the shaft and hub to give 3/4". Tighten both 3/4" jam nuts.

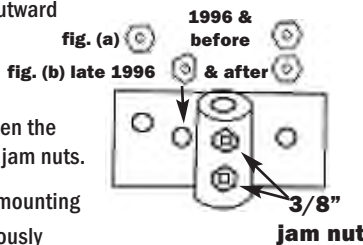

Step #3: Now you are ready to install the shaft into the mounting bracket. Depth and pitch will be set simultaneously before set bolts are tightened. Set the depth of shaft at 5 1/2" (**fig. (d)**). Set 3/4" minimum pitch to fill the furrow with soil.

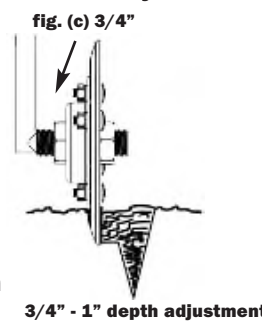

Step #4: Use the gauging tool to help in setting correct pitch. This is provided with every 2 rows ordered. Place the gauging tool over the shaft. Turn gauging tool counter clockwise until gauge pin bumps against the back of the FVC mounting bracket (**fig. (e)**). Line up mark on gauging tool with mark on shaft. This equals a 3/4" pitch. With depth and pitch set, tighten square headed set bolts into shaft.

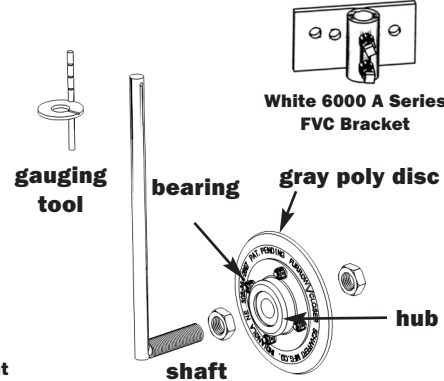

Step #5: Poly disc will rest on the gauge wheel tire without harming it when planter is raised. When optional steel disc is used, a travel stop must be put on the gauge wheel so that the steel disc will not cut the tire when planter is raised.

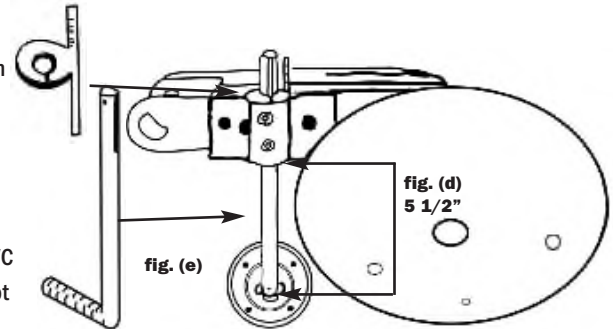

White 6000 & 8000 Series A FVC Package Contents (per single row)	
HARDWARE KIT	
Item	Quantity
1/4 x 3/4 carriage bolts*	4
1/4 nuts*	4
1/4 lock washer*	4
1/8" x 1" cotter pin	1
3/8 x 5 1/2 bolt	1
3/8 x 1 1/4 bolts	2
3/8 lock nut	3
3/8 lock washer	3
3/8" jam nut	2
3/4" jam nut	2
3/8 x 1 setscrews*	2
Gauging tool (per box of 2)	1
Instruction Sheet	1
PARTS LIST	
Item & Part #	Quantity
Gray Poly Disc (1002)	1
Steel Disc (optional - 1003)	1
Hub (2001)	1
Bearing triple seal (3001)	1
Shaft (4001)	1
Mt. Bracket (5003)	1
*NOTE: some hardware is installed at the factory.	

Important Points to Remember:

- When setting the pitch of the Furrow V Closer; lift the gauge wheel up so the FVC disc can properly be pitched. Gauge wheel tire will rest on FVC disc and will not hurt it.