

## REBOUNDER™ MOUNTING INSTRUCTIONS

### Montezuma

(Read Instructions Completely before Beginning Installation)

**Before working on your planter or drill**

**DANGER:** when storing or working on the planter always install cylinder stops or place the planter on stands to prevent personal injury or damage to the Rebounder. **WARNING:** do not roll back or back up the planter in or on the ground as this can result in damage to the Rebounder.

### Mounting Instructions

**Before you begin, verify all items listed in the “package contents” table.**

**NOTE: See HELPFUL HINTS FOR MOUNTING REBOUNDERS TO DRILLS.**

- Step #1:** begin as low as possible by welding the bottom of the 1/4” bin cup bolt to the bottom of the boot.
- Step #2:** position the bracket with the top bolt and tack the bolt in place.
- Step #3:** finish by welding the bolt to the mounted seed boot and bolt the Rebounder to the bracket with the 1/4” bolts.
- Step #4:** set the tail end of the Rebounder 3/8” to 1/2” from the bottom of the furrow.
- Step #5:** SEE HELPFUL HINTS FOR MOUNTING REBOUNDERS TO DRILLS.

**Optional fittings are available for fertilizer/chemical applications. Options include, Y-Not Split-It, Hose Holder, or the Straight Shot, each available for an additional charge.**

Rebounder Package Contents (per single row)	
Item	Quantity
Rebounder . . . . .	1
1/4 x 1” Bolt . . . . .	2
L-bracket . . . . .	1
Whiz Nut . . . . .	2
Instruction Sheet . . . . .	1
Bracket Package Contents (per single row)	
Item	Quantity
Bracket . . . . .	1
1/4 Bin Cup Bolt . . . . .	2
Lock Nut . . . . .	2

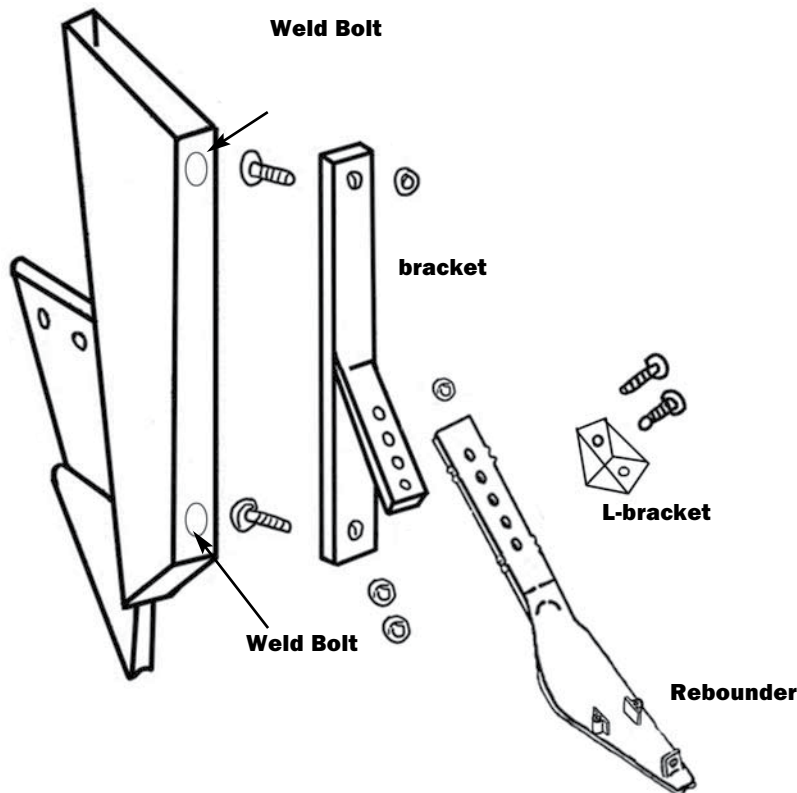

## HELPFUL HINTS FOR MOUNTING THE REBOUNDER™ ON DRILLS

(Read Instructions Completely before Beginning Installation)

### Before working on your planter or drill

**DANGER:** when storing or working on the planter always install cylinder stops or place the planter on stands to prevent personal injury or damage to the Rebounder. **WARNING:** do not roll back or back up the planter in or on the ground as this can result in damage to the Rebounder.

### Helpful Hints

- Step #1:** use a farm jack on the press wheel to raise up the drill unit 3-4" before you mount the first row.  
**IMPORTANT:** have press wheel adjusting handle of knob, in the position you would normally run in the field (see **fig (a)**).
- Step #2:** slide a board or piece of flat iron under the double disc openers and back under the press wheel tire. The board or flat iron represents the bottom of the seed V.
- Step #3:** now you can bolt the Rebounder to the bracket on the drill. Position the Rebounder on the bracket so that the trailing end will be from 3/8" - 1/2" off the board or flat iron. Using the 1/4" bolts attach the Rebounder to the bracket on the drill.
- Step #4:** variances in the disc blade size will occur among individual drills as well as within any single drill. Measure discs behind the tire track rows. If they are worn more than other rows this process may need to be used to set these rows also.
- Step #5:** if replacing Rebounders on previously installed brackets, simply remove the old Rebounder without removing the disc blade. Using a small bar magnet or a long handled magnet, place the bolt on the magnet and slide it up between the discs and into the holes of the bracket and the Rebounder. This allows you to come in behind with a wrench or socket to install and tighten the nuts.

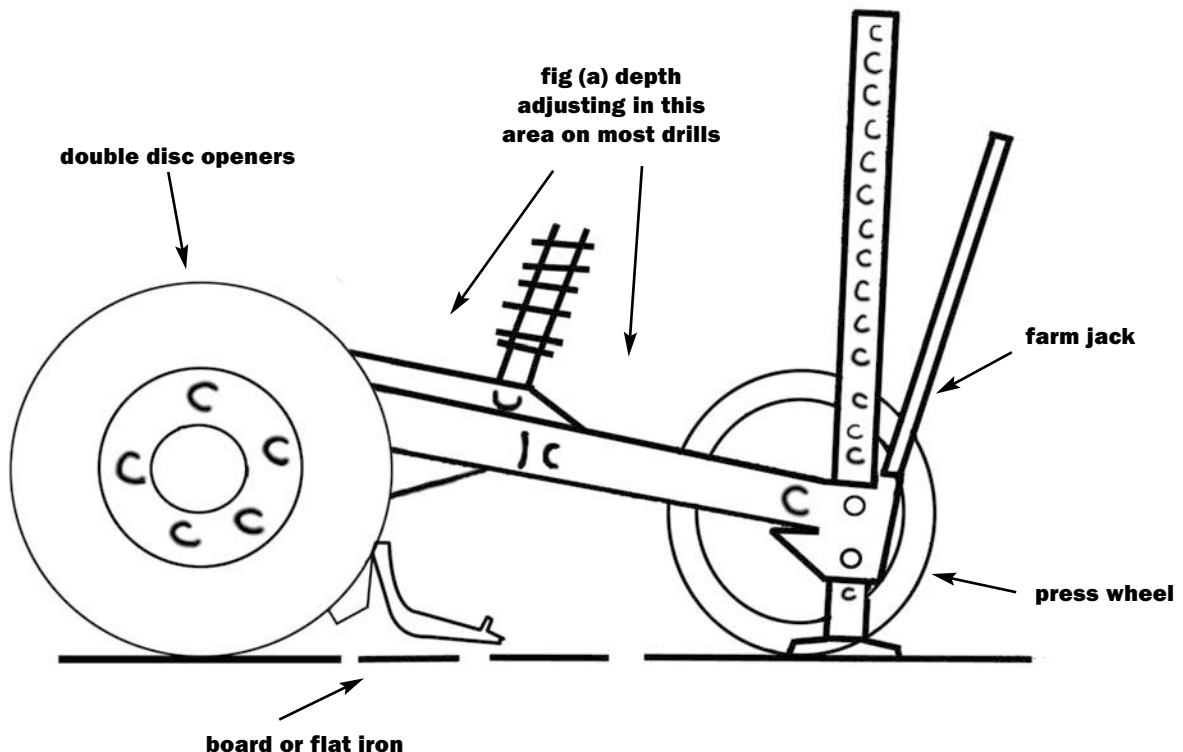

Rebounder covered by one or more of the following U.S. patents: 5,640,915; 5,918,557; 6,082,275; 6,283,050; 6,453,832; 6,763,773 and 7,121,216.