

REBOUNDER® MOUNTING INSTRUCTIONS

A/C 78-79 Air Planters

Before working on your planter or drill

DANGER: When storing or working on the planter always install cylinder stops or place the planter on stands to prevent personal injury or damage to the attachments.

PLEASE: Read instructions completely and verify all package contents before beginning installation

NOTE: If applying liquids in furrow with the Rebounder, attach either Y-Not Split It, Hose Holder, or Straight Shot kit by following kit directions.
INSTALL KIT BEFORE INSTALLING REBOUNDER TO PLANTER UNIT. See kit instructions.

Rebounder Package Contents (per single row)	
Item	Quantity
Rebounder	1
5/16 x 1" bolt	1
5/16" lock nut	1
fender washer	1
Instruction Sheet	1
Bracket Package Contents (per single row)	
Item	Quantity
Bracket	1
5/16" bolts	2
5/16" Nuts	2

STEP #1:

Take the seed boot extension off and remove the rubber flap, then re-attach the boot. Bolt the Rebounder bracket in place with the two bolts.

STEP #2:

Attach the Rebounder with the bolt, fender washer and nut.

STEP #3:

Set the planter on a flat surface. The tail of the Rebounder should be about 3/8" off the floor or flat surface. Tighten the nut on the Rebounder.

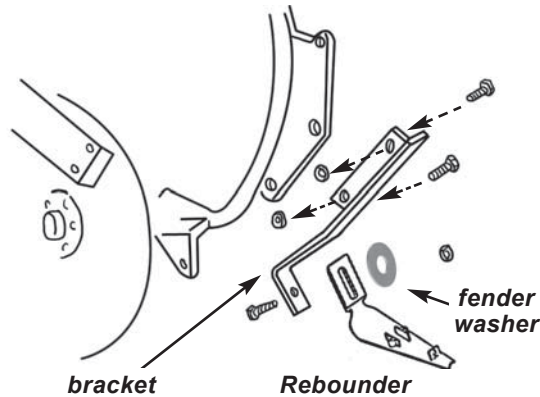

REBOUNDER WITH FURROW V CLOSER

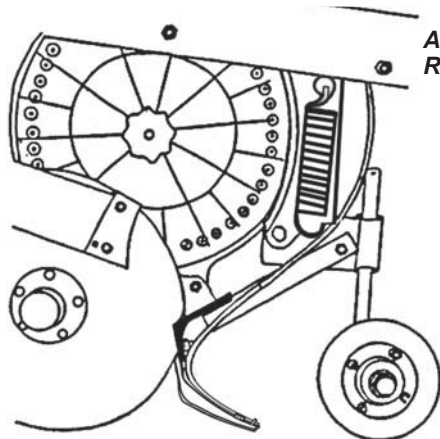

A/C 78 & 79 Air Planter with Rebounder & Furrow V Closer

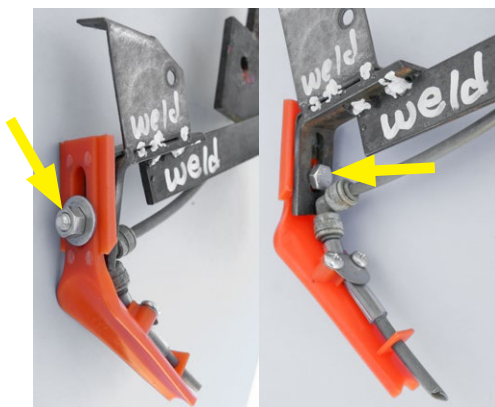
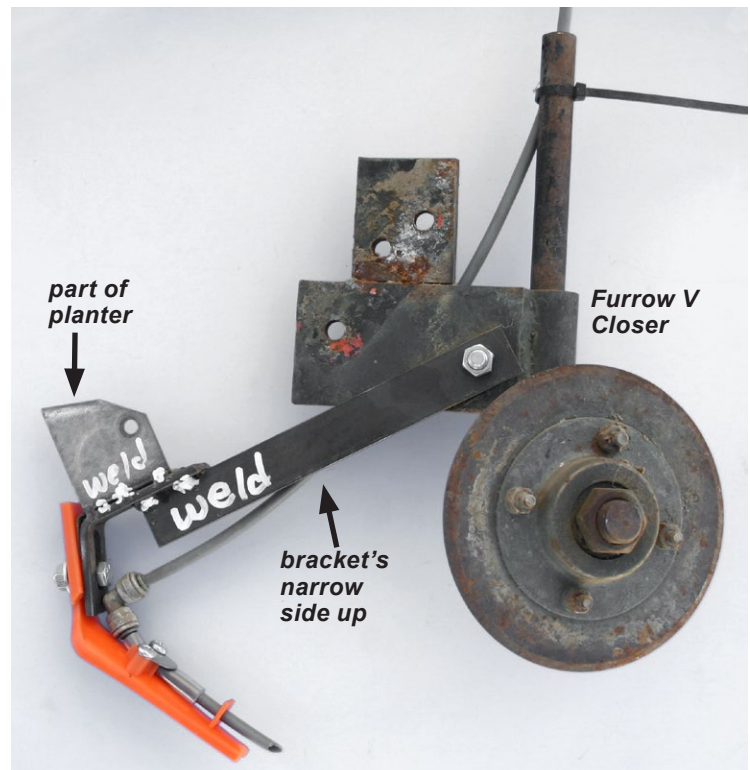

Slide Rebounder all the way up so the bolt is at the bottom of the slot. The bolt should be at the bottom of the slot on the bracket as well.

FURROW V CLOSER MOUNTING INSTRUCTIONS

A/C 78-79 Air Planters

Before working on your planter or drill

DANGER: When storing or working on the planter always install cylinder stops or place the planter on stands to prevent personal injury or damage to the attachments.

PLEASE: Read instructions completely and verify all package contents before beginning installation

Step #1: Mount the FVC bracket to the planter unit using two 3/8" x 1-1/2" nuts and bolts (fig. (a)).

Step #2: assemble the disc to shaft with two 3/4" jam nuts so the disc is approximately 1-3/4" from the shaft. The bearing needs to be toward the outside (fig. (b)).

Step #3: position the shaft into the mounting bracket so that there is approximately 1" pitch out on the front of the disc (fig. (c)). Set the disc (with the planter in the soil) to a depth of 1/2" (3/4" max.) (fig. (d)). Tighten the set screws making minor adjustments to the Furrow V Closer while in the field. This will depend on the planting depth, speed and conditions. Re-check and tighten all nuts, bolts, and set screws.

A/C 78-79 Air Planters FVC Package Contents (per single row)	
HARDWARE KIT	
Item	Quantity
3/8" x 1-1/2" bolts.....	2
3/4 jam nuts.....	2
Instruction Sheet.....	1
PARTS LIST	
Item & Part #	Quantity
*NOTE: some hardware is installed at the factory.	

Important Points to Remember:

- When setting the pitch of the Furrow V Closer; lift the gauge wheel up so the FVC disc can properly be pitched. Gauge wheel tire will rest on FVC disc and will not hurt it.

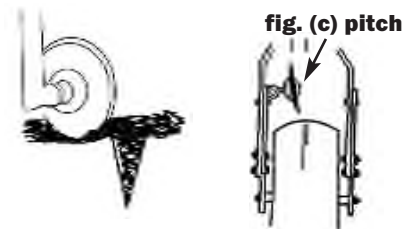

fig. (c) pitch adjustment

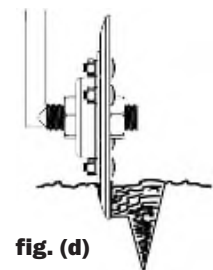

fig. (d)

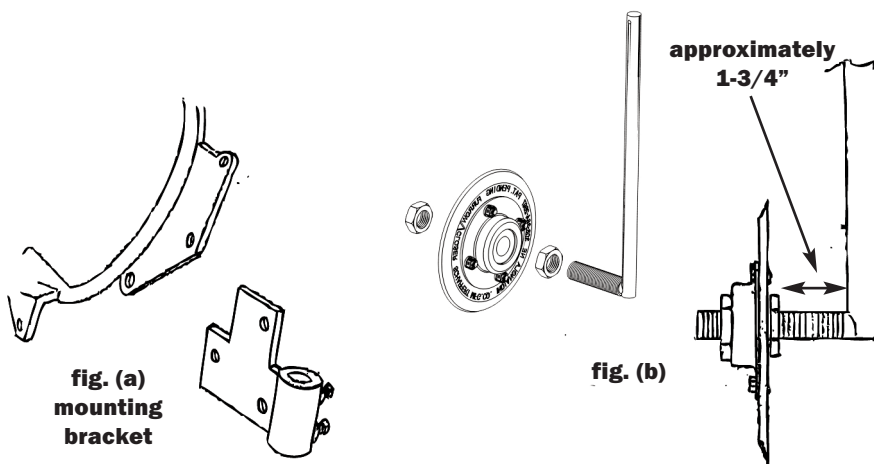

fig. (a)
mounting
bracket

fig. (b)

approximately
1-3/4"