

# PRESS WHEEL SCRAPER MOUNTING INSTRUCTIONS

## Case IH 800 – 1250 Planters with Furrow V Closer

Before working on your planter or drill

**DANGER:** When storing or working on the planter always install cylinder stops or place the planter on stands to prevent personal injury or damage to the attachments.

**PLEASE:** Read instructions completely and verify all package contents before beginning installation.

IH 800-1250 Press Wheel Scraper with Furrow V Closer	
Package Contents for part #: PWSIHFCV	
Qty	Item
1	Mounting Bracket
4	3/8" x 1" Bolt
4	3/8" Lock Nut
1	IH Plastic Scraper
2	1/4" x 1" Whiz Bolt
2	1/4" Whiz Nut
1	Instruction Sheet

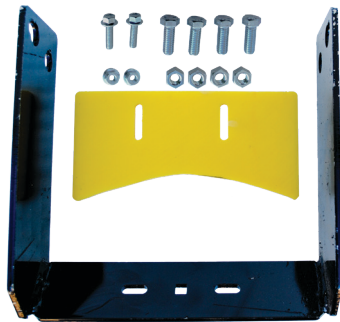

OR

IH 800-1250 Chicken Tracker Scraper with Furrow V Closer	
Package Contents for part #: PWSCTFVC	
Qty	Item
1	Mounting Bracket
4	3/8" x 1" Bolt
4	3/8" Lock Nut
1	CT Plastic Scraper
2	1/4" x 1" Whiz Bolt
2	1/4" Whiz Nut
1	Instruction Sheet

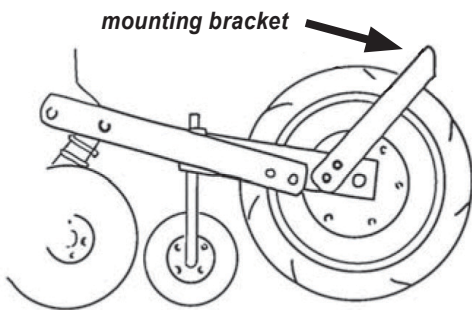

### STEP #1:

Use the four 3/8" bolts and lock nuts to bolt the scraper bracket to the press wheel arm bracket.

### STEP #2:

Loosely bolt the plastic scraper to the top side of the mounting bracket with the 1/4" whiz bolts and 1/4" whiz nuts.

The bolts go through from behind the bracket and the nuts should be placed on top the plastic scraper piece.

Adjust the scraper as needed to wipe the mud off the press wheel, and tighten the nuts.

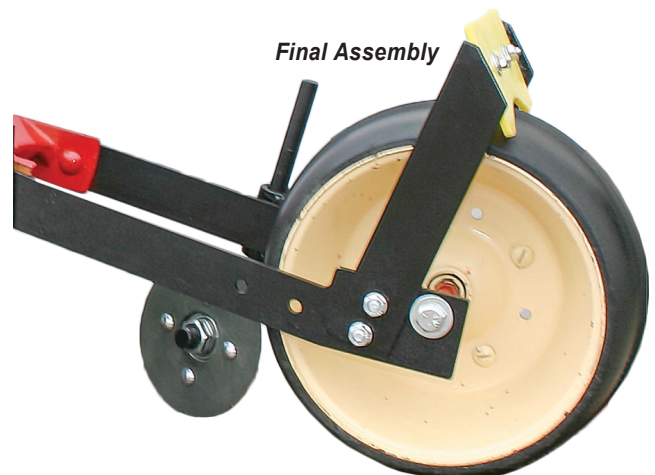
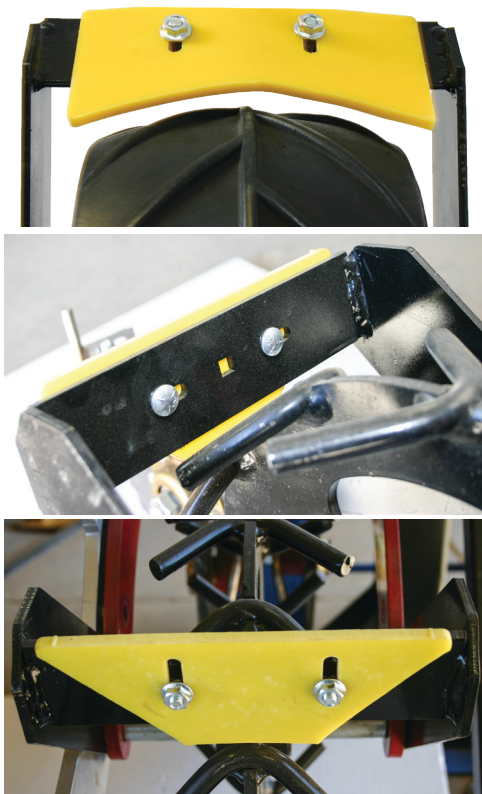

Case IH 800-1250 OEM press wheel with Furrow V Closer