

# PRESS WHEEL SCRAPER MOUNTING INSTRUCTIONS

Case IH 800 900 950 955 1200 1250 Planters

Before working on your planter or drill

**DANGER:** When storing or working on the planter always install cylinder stops or place the planter on stands to prevent personal injury or damage to the attachments.

**PLEASE:** Read instructions completely and verify all package contents before beginning installation.

## IH 800-1250 Press Wheel Scraper

Package Contents for part #: PWSIH12

Qty	Item
1	Mounting Bracket
2	1/2" x 1" Bolt
2	1/2" Nut
1	IH Plastic Scraper
2	1/4" x 1" Whiz Bolt
2	1/4" Whiz Nut
1	Instruction Sheet

**NOTE:** The following instructions are for mounting press wheel scrapers to Case IH 800-1250 planters that **do not** have the Furrow V Closer.

If your planter has the FVC, please refer to Press Wheel Scraper Mounting Instructions: Case IH 800-1250 Planters with Furrow V Closer



**NOTE:** The scraper mounting bracket for Case IH 800-1250 planters has two holes on each side and is wider than the scraper mounting bracket for Case IH 2100 planters, which is 1/2" narrower with three holes on each side.

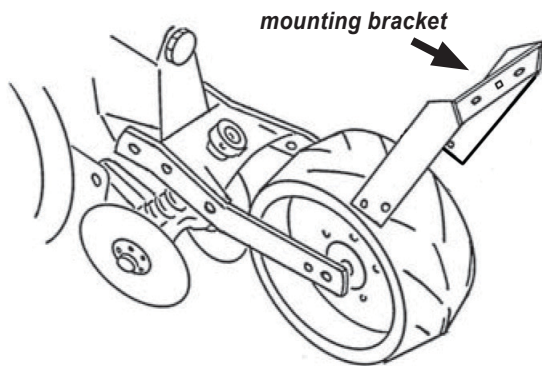

## STEP #1:

Using the two 1/2" bolts and 1/2" nuts, and the existing press wheel bolt: Bolt the scraper bracket to the press wheel arm bracket.

## STEP #2:

Loosely bolt the plastic scraper to the top side of the mounting bracket with the 1/4" whiz bolts and 1/4" whiz nuts.

The bolts go through from behind the bracket and the nuts should be placed on top the plastic scraper piece.

Adjust the scraper as needed to wipe the mud off the press wheel, and tighten the nuts.

Case IH 800-1250 without Furrow V Closer

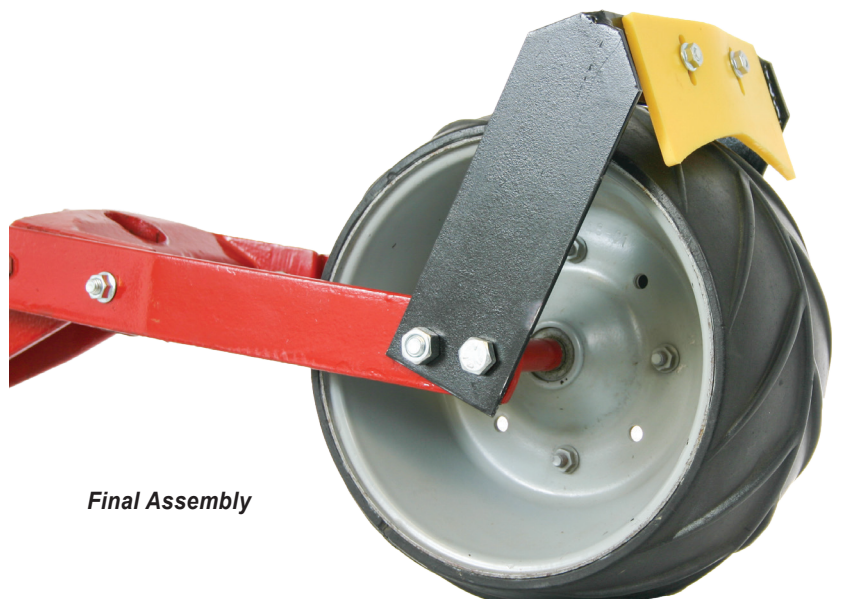

Final Assembly

